

HCT/ATEX

Vahvarakenteiset pitkärunkoiset aksiaalipuhaltimet.
ATEX-luokiteltu, käytettäväksi räjähdysvaarallisissa tiloissa



Ilmoitettu organismi: LOM
 Tunnistenumero: LOM 03ATEX0157
 Moottorin merkintä:
 Ⓜ II 2G Ex db IIB T4 Gb
 Ⓜ II 2G Ex eb IIB T3 Gb
 Ⓜ II 2D Ex tb IIIC T135 °C Db



Pitkärunkoiset aksiaalipuhaltimet. ATEX-luokiteltu, II2G-laiteluokka, räjähdyspaineen kestävällä Ex db -moottorilla tai varmennetun rakenteen Ex eb -moottorilla, tai II2D-laiteluokka pölysuojatulla Ex tb -moottorilla.

Puhallin:

- Runko terästä. Alumiinivanne siipipyörän kohdalla estämässä kipinöintiä EN 14986 mukaisesti.
- Siipipyörä alumiinivalua.
- Sisältää huoltoluukun.
- Puhallussuunta moottorista siipipyörään päin.

Moottori:

- F-eristysluokan moottorit kuulalaakereilla ja ATEX-luokiteltu, räjähdyspaineen kestävä Ex db, varmennettu rakenne Ex eb tai pölysuojattu Ex tb.

- Kolmivaiheinen 230/400 V 50 Hz (4 kW moottoritehoon asti), tai 400/690 V 50 Hz (yli 4 kW moottoritehoilla).
- Käyttölämpötila: -20 °C...+40 °C.

Pintakäsittely:

- Polyesterijauhemaalaus ATEX-käyttöön soveltuvalla maalilla, RAL 7032. Pohjakäsittelynä rasvanpoisto fosfaatitonta nanoteknologiaa käyttäen.

Pyynnöstä:

- PTC-termistorit käämeissä.
- Erikoiskäämitykset eri jännitteille ja taajuuksille.
- Puhaltimet 2-nopeusmoottorilla.
- Yksivaiheiset räjähdyspaineenkestävät Ex db moottorit.

Tilauskoodi

HCT/ATEX	–	56	–	4T	/	1.5	/	2G Ex eb
↓		↓		↓		↓		↓
HCT/ATEX: Vahvarakenteiset pitkärunkoiset aksiaalipuhaltimet. ATEX-luokiteltu, käytettäväksi räjähdysvaarallisissa tiloissa		Siipipyörän halkaisija cm		Moottorin napojen määrä 2=3000 rpm 50 Hz 4=1500 rpm 50 Hz 6=1000 rpm 50 Hz	T = Kolmivaiheinen	Moottoriteho (hv)		2G Ex eb: Pölysuojattu, tilaluokka 1 ja 2 2G Ex db: Pölysuojattu, tilaluokka 1 ja 2 2D Ex tb: Pölysuojattu, tilaluokka 21 ja 22

Tekniset ominaisuudet

Malli	Pyörimisnopeus (rpm)	Nimellisvirta (A)			Moottoriteho (kW)	Maks. ilmamäärä (m³/h)	Äänenpainetaso¹ dB (A)	Paino noin (Kg)	
		230V	400V	690V				Ex eb	Ex db
HCT/ATEX-35-2T	2770	1,62	0,93		0,37	5885	67	13	23
HCT/ATEX-35-4T	1400	1,28	0,74		0,12	3210	49	12	19
HCT/ATEX-40-2T-1.5	2850	3,93	2,26		1,10	8805	74	27	40
HCT/ATEX-40-4T-0.33	1370	1,25	0,72		0,25	5175	54	21	30
HCT/ATEX-45-2T-2	2800	5,67	3,26		1,50	10630	77	30	49
HCT/ATEX-45-2T-3	2860	8,73	5,02		2,20	12745	79	33	54
HCT/ATEX-45-4T-0.5	1370	2,60	1,50		0,37	7100	59	25	33
HCT/ATEX-50-4T-0.75	1410	2,87	1,65		0,55	10380	63	27	41
HCT/ATEX-56-4T-0.75	1410	2,87	1,65		0,55	11040	65	32	46
HCT/ATEX-56-4T-1	1410	3,81	2,20		0,75	12940	66	34	47
HCT/ATEX-56-4T-1.5	1410	4,54	2,61		1,10	13995	67	36	55
HCT/ATEX-56-4T-2	1400	6,93	4,00		1,50	15290	68	39	59

Tekniset ominaisuudet

Malli	Pyörimisnopeus (rpm)	Nimellisvirta (A)			Moottoriteho (kW)	Maks. ilmamäärä (m ³ /h)	Äänenpainetaso ¹ dB (A)		Paino noin (Kg)	
		230V	400V	690V			lmupuoli	Ex eb	Ex db	
HCT/ATEX-56-6T-0.33	910	2,42	1,40		0,25	8500	54	31	39	
HCT/ATEX-56-6T-0.5	935	2,77	1,60		0,37	9300	54	34	43	
HCT/ATEX-56-6T-0.75	930	3,46	2,00		0,55	9995	55	34	47	
HCT/ATEX-63-4T-1	1410	3,81	2,20		0,75	14145	68	43	56	
HCT/ATEX-63-4T-1.5	1410	4,54	2,61		1,10	17020	69	45	64	
HCT/ATEX-63-4T-2	1400	6,93	4,00		1,50	18910	70	48	68	
HCT/ATEX-63-4T-3	1410	8,30	4,77		2,20	22090	71	53	76	
HCT/ATEX-63-4T-4	1440	11,27	6,48		3,00	25390	72	56	79	
HCT/ATEX-63-6T-0.5	935	2,77	1,60		0,37	12135	59	43	52	
HCT/ATEX-63-6T-0.75	930	3,46	2,00		0,55	12760	60	43	56	
HCT/ATEX-71-4T-1.5	1410	4,54	2,61		1,10	19770	73	51	70	
HCT/ATEX-71-4T-2	1400	6,93	4,00		1,50	21090	74	54	74	
HCT/ATEX-71-4T-3	1410	8,30	4,77		2,20	23970	76	60	83	
HCT/ATEX-71-4T-4	1440	11,27	6,48		3,00	29410	77	63	86	
HCT/ATEX-71-6T-0.75	930	3,46	2,00		0,55	15130	62	49	62	
HCT/ATEX-71-6T-1	930	4,16	2,40		0,75	17260	63	51	70	
HCT/ATEX-71-6T-1.5	910	5,89	3,40		1,10	20965	64	54	75	
HCT/ATEX-80-4T-3	1410	8,30	4,77		2,20	27940	77	69	92	
HCT/ATEX-80-4T-4	1440	11,27	6,48		3,00	32720	78	72	95	
HCT/ATEX-80-4T-5.5	1450	15,29	8,79		4,00	37440	79	74	98	
HCT/ATEX-80-6T-1	930	4,16	2,40		0,75	20560	66	60	79	
HCT/ATEX-80-6T-1.5	910	5,89	3,40		1,10	24650	67	63	84	
HCT/ATEX-80-6T-2	940	7,62	4,40		1,50	27960	68	71	95	
HCT/ATEX-80-6T-3	940	9,35	5,40		2,20	32545	69	74	98	
HCT/ATEX-90-4T-4	1440	11,27	6,48		3,00	37635	83	87	110	
HCT/ATEX-90-4T-5.5	1450	15,29	8,79		4,00	41810	85	90	114	
HCT/ATEX-90-4T-7.5	1440		10,64	18,50	5,50	47550	87	103	142	
HCT/ATEX-90-4T-10	1450		14,39	25,03	7,50	53120	88	111	145	
HCT/ATEX-90-6T-3	940	9,35	5,40		2,20	35555	74	90	114	
HCT/ATEX-90-6T-4	945	14,72	8,50		3,00	40165	75	102	142	
HCT/ATEX-100-4T-7.5	1440		10,64	18,50	5,50	52470	90	115	154	
HCT/ATEX-100-4T-10	1450		14,39	25,03	7,50	58560	91	122	156	
HCT/ATEX-100-4T-15	1460		20,76	36,10	11,00	68000	92	159	256	
HCT/ATEX-100-4T-20	1450		28,19	49,03	15,00	71850	93	178	279	
HCT/ATEX-100-6T-3	940	9,35	5,40		2,20	40390	80	101	125	
HCT/ATEX-100-6T-4	945	14,72	8,50		3,00	46960	81	113	153	
HCT/ATEX-100-6T-5.5	950	18,88	10,90		4,00	52025	82	120	156	

1. Äänenpainetaso dB(A) 3 m etäisyydellä vapaassa kentässä.

Äänitiedot

Äänitehotasot Lw(A) [dB(A)] oktaavikaistoittain (Hz).
Arvot mitattu sisääntulon aikana enimmäisvirtausnopeudella

	63	125	250	500	1000	2000	4000	8000		63	125	250	500	1000	2000	4000	8000
HCT/ATEX-35-2T	48	63	82	81	82	81	76	67	HCT/ATEX-56-6T-0.33	36	56	64	69	71	68	61	50
HCT/ATEX-35-4T	30	45	64	63	64	63	58	49	HCT/ATEX-56-6T-0.5	36	56	64	69	71	68	61	50
HCT/ATEX-40-2T-1.5	55	70	89	88	89	88	83	74	HCT/ATEX-56-6T-0.75	37	57	65	70	72	69	62	51
HCT/ATEX-40-4T-0.33	35	50	69	68	69	68	63	54	HCT/ATEX-63-4T-1	50	70	78	83	85	82	75	64
HCT/ATEX-45-2T-2	51	68	80	88	93	93	89	82	HCT/ATEX-63-4T-1.5	51	71	79	84	86	83	76	65
HCT/ATEX-45-2T-3	53	70	82	90	95	95	91	84	HCT/ATEX-63-4T-2	52	72	80	85	87	84	77	66
HCT/ATEX-45-4T-0.5	33	50	62	70	75	75	71	64	HCT/ATEX-63-4T-3	53	73	81	86	88	85	78	67
HCT/ATEX-50-4T-0.75	37	54	67	74	79	80	75	68	HCT/ATEX-63-4T-4	54	74	82	87	89	86	79	68
HCT/ATEX-56-4T-0.75	47	67	75	80	82	79	72	61	HCT/ATEX-63-6T-0.5	41	61	69	74	76	73	66	55
HCT/ATEX-56-4T-1	48	68	76	81	83	80	73	62	HCT/ATEX-63-6T-0.75	42	62	70	75	77	74	67	56
HCT/ATEX-56-4T-1.5	49	69	77	82	84	81	74	63	HCT/ATEX-71-4T-1.5	55	75	83	88	90	87	80	69
HCT/ATEX-56-4T-2	50	70	78	83	85	82	75	64	HCT/ATEX-71-4T-2	56	76	84	89	91	88	81	70

Äänitiedot

Äänitehotasot Lw(A) [dB(A)] oktaavikaistoittain (Hz).
Arvot mitattu sisääntulon aikana enimmäisvirtausnopeudella

	63	125	250	500	1000	2000	4000	8000
HCT/ATEX-71-4T-3	58	78	86	91	93	90	83	72
HCT/ATEX-71-4T-4	59	79	87	92	94	91	84	73
HCT/ATEX-71-6T-0.75	44	64	72	77	79	76	69	58
HCT/ATEX-71-6T-1	45	65	73	78	80	77	70	59
HCT/ATEX-71-6T-1.5	46	66	74	79	81	78	71	60
HCT/ATEX-80-4T-3	59	79	87	92	94	91	84	73
HCT/ATEX-80-4T-4	60	80	88	93	95	92	85	74
HCT/ATEX-80-4T-5.5	61	81	89	94	96	93	86	75
HCT/ATEX-80-6T-1	48	68	76	81	83	80	73	62
HCT/ATEX-80-6T-1.5	49	69	77	82	84	81	74	63
HCT/ATEX-80-6T-2	50	70	78	83	85	82	75	64
HCT/ATEX-80-6T-3	51	71	79	84	86	83	76	65
HCT/ATEX-90-4T-4	65	86	93	98	101	97	90	79

	63	125	250	500	1000	2000	4000	8000
HCT/ATEX-90-4T-5.5	67	88	95	100	103	99	92	81
HCT/ATEX-90-4T-7.5	69	90	97	102	105	101	94	83
HCT/ATEX-90-4T-10	70	91	98	103	106	102	95	84
HCT/ATEX-90-6T-3	56	77	84	89	92	88	81	70
HCT/ATEX-90-6T-4	57	78	85	90	93	89	82	71
HCT/ATEX-100-4T-7.5	72	92	100	105	107	104	97	86
HCT/ATEX-100-4T-10	73	93	101	106	108	105	98	87
HCT/ATEX-100-4T-15	74	94	102	107	109	106	99	88
HCT/ATEX-100-4T-20	75	95	103	108	110	107	100	89
HCT/ATEX-100-6T-3	62	82	90	95	97	94	87	76
HCT/ATEX-100-6T-4	63	83	91	96	98	95	88	77
HCT/ATEX-100-6T-5.5	64	84	92	97	99	96	89	78

Mitat mm

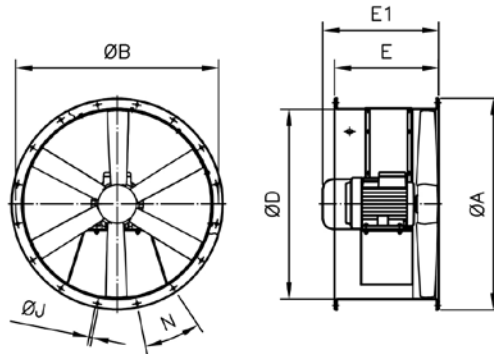

	ØA	ØB	ØD	E	E1	ØJ	N
HCT/ATEX-35-2T	425	395	355	280	306	10	8x45°
HCT/ATEX-35-4T	425	395	355	280	322	10	8x45°
HCT/ATEX-40-2T-1.5	490	450	410	400	400	12	8x45°
HCT/ATEX-40-4T-0.33	490	450	410	400	400	12	8x45°
HCT/ATEX-45-2T-2	540	500	460	400	422	12	8x45°
HCT/ATEX-45-2T-3	540	500	460	400	422	12	8x45°
HCT/ATEX-45-4T-0.5	540	500	460	400	400	12	8x45°
HCT/ATEX-50-4T-0.75	600	560	514	400	400	12	12x30°
HCT/ATEX-56-4T-0.75	660	620	560	400	400	12	12x30°
HCT/ATEX-56-4T-1	660	620	560	400	400	12	12x30°
HCT/ATEX-56-4T-1.5	660	620	560	400	422	12	12x30°
HCT/ATEX-56-4T-2	660	620	560	400	422	12	12x30°
HCT/ATEX-56-6T-0.33	660	620	560	400	400	12	12x30°
HCT/ATEX-56-6T-0.5	660	620	560	400	400	12	12x30°
HCT/ATEX-56-6T-0.75	660	620	560	400	400	12	12x30°
HCT/ATEX-63-4T-1	730	690	640	400	400	12	12x30°
HCT/ATEX-63-4T-1.5	730	690	640	400	422	12	12x30°
HCT/ATEX-63-4T-2	730	690	640	400	422	12	12x30°
HCT/ATEX-63-4T-3	730	690	640	500	500	12	12x30°
HCT/ATEX-63-4T-4	730	690	640	500	500	12	12x30°
HCT/ATEX-63-6T-0.5	730	690	640	400	400	12	12x30°
HCT/ATEX-63-6T-0.75	730	690	640	400	400	12	12x30°
HCT/ATEX-71-4T-1.5	810	770	710	430	442	12	16x22°30'
HCT/ATEX-71-4T-2	810	770	710	430	442	12	16x22°30'
HCT/ATEX-71-4T-3	810	770	710	500	500	12	16x22°30'

	ØA	ØB	ØD	E	E1	ØJ	N
HCT/ATEX-71-4T-4	810	770	710	500	500	12	16x22°30'
HCT/ATEX-71-6T-0.75	810	770	710	430	430	12	16x22°30'
HCT/ATEX-71-6T-1	810	770	710	500	442	12	16x22°30'
HCT/ATEX-71-6T-1.5	810	770	710	500	442	12	16x22°30'
HCT/ATEX-80-4T-3	900	860	800	500	500	12	16x22°30'
HCT/ATEX-80-4T-4	900	860	800	500	500	12	16x22°30'
HCT/ATEX-80-4T-5.5	900	860	800	500	519	12	16x22°30'
HCT/ATEX-80-6T-1	900	860	800	500	500	12	16x22°30'
HCT/ATEX-80-6T-1.5	900	860	800	500	500	12	16x22°30'
HCT/ATEX-80-6T-2	900	860	800	500	500	12	16x22°30'
HCT/ATEX-80-6T-3	900	860	800	500	519	12	16x22°30'
HCT/ATEX-90-4T-4	1015	970	900	600	600	15	16x22°30'
HCT/ATEX-90-4T-5.5	1015	970	900	600	600	15	16x22°30'
HCT/ATEX-90-4T-7.5	1015	970	900	600	636	15	16x22°30'
HCT/ATEX-90-4T-10	1015	970	900	600	716	15	16x22°30'
HCT/ATEX-90-6T-3	1015	970	900	600	600	15	16x22°30'
HCT/ATEX-90-6T-4	1015	970	900	600	636	15	16x22°30'
HCT/ATEX-100-4T-7.5	1115	1070	1000	600	636	15	16x22°30'
HCT/ATEX-100-4T-10	1115	1070	1000	600	716	15	16x22°30'
HCT/ATEX-100-4T-15	1115	1070	1000	700	738	15	16x22°30'
HCT/ATEX-100-4T-20	1115	1070	1000	700	738	15	16x22°30'
HCT/ATEX-100-6T-3	1115	1070	1000	600	600	15	16x22°30'
HCT/ATEX-100-6T-4	1115	1070	1000	600	636	15	16x22°30'
HCT/ATEX-100-6T-5.5	1115	1070	1000	600	716	15	16x22°30'

Mitat pätevät Ex eb mootorilla.

Ominaiskäyrät

Q= Ilmamäärä m³/h, m³/s ja cfm

Pe= Staattinen paine mmH₂O, Pa ja inwg

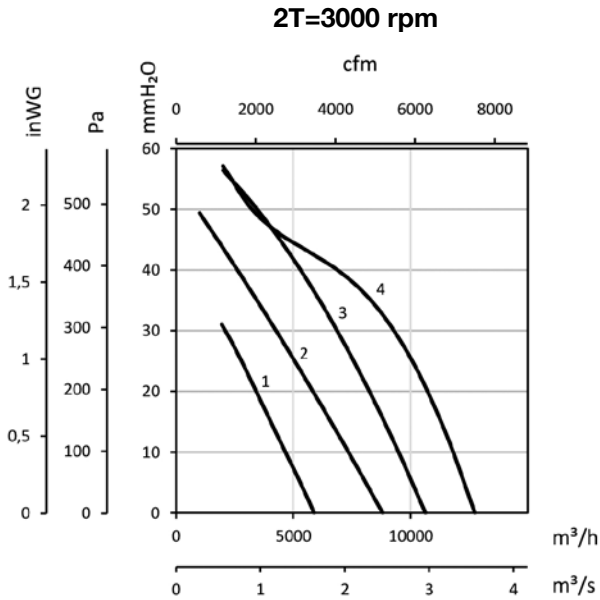

- 1 : HCT/ATEX-35-2T
- 2 : HCT/ATEX-40-2T-1.5
- 3 : HCT/ATEX-45-2T-2
- 4 : HCT/ATEX-45-2T-3

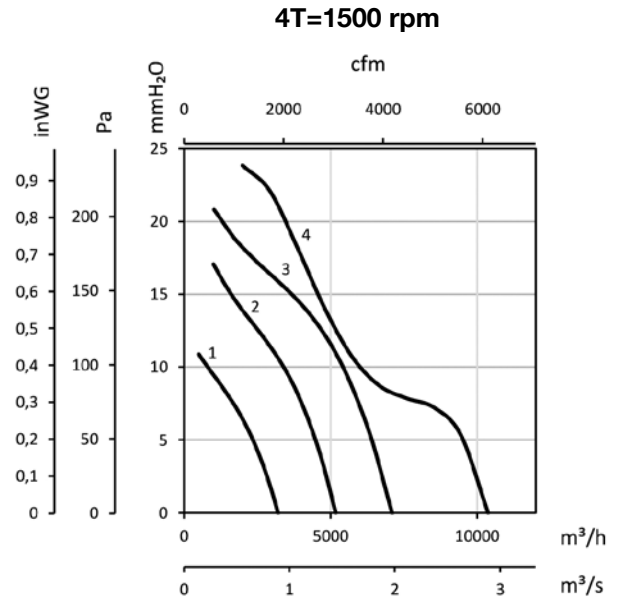

- 1 : HCT/ATEX-35-4T
- 2 : HCT/ATEX-40-4T-0.33
- 3 : HCT/ATEX-45-4T-0.5
- 4 : HCT/ATEX-50-4T-0.75

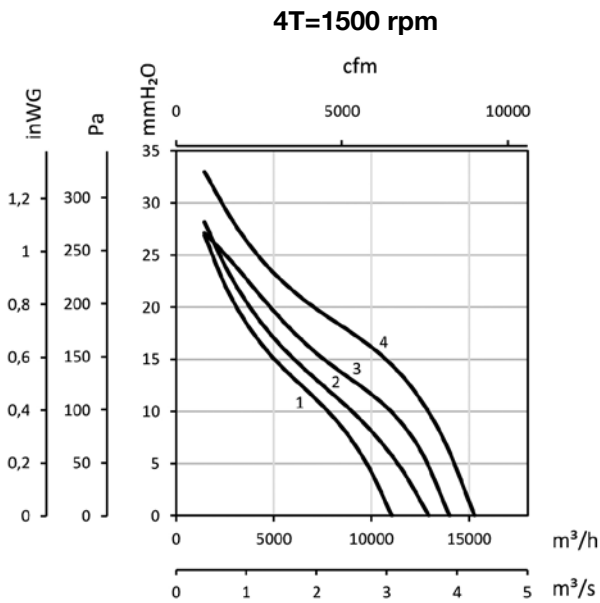

- 1 : HCT/ATEX-56-4T-0.75
- 2 : HCT/ATEX-56-4T-1
- 3 : HCT/ATEX-56-4T-1.5
- 4 : HCT/ATEX-56-4T-2

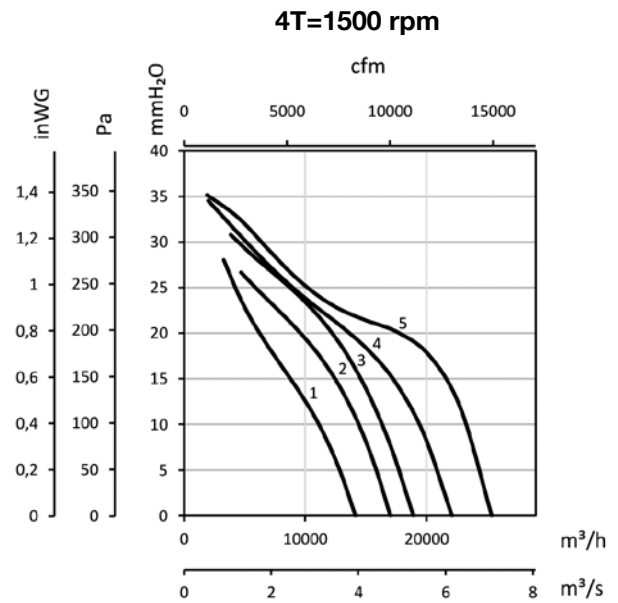

- 1 : HCT/ATEX-63-4T-1
- 2 : HCT/ATEX-63-4T-1.5
- 3 : HCT/ATEX-63-4T-2
- 4 : HCT/ATEX-63-4T-3
- 5 : HCT/ATEX-63-4T-4

Ominaiskäyrät

Q= Ilmamäärä m³/h, m³/s ja cfm

Pe= Staattinen paine mmH₂O, Pa ja inwg

4T=1500 rpm

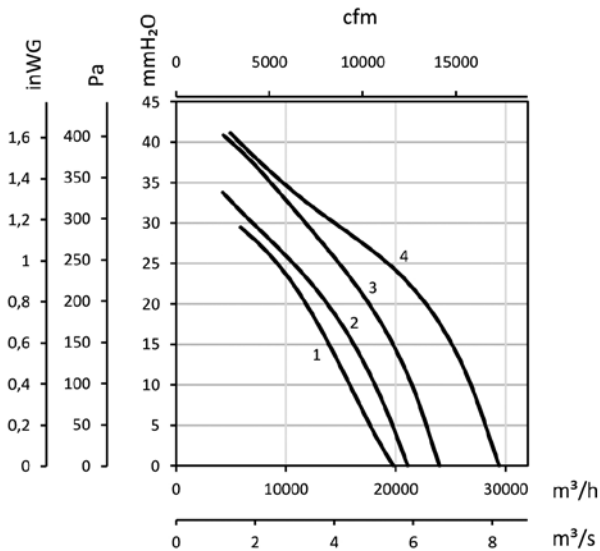

- 1 : HCT/ATEX-71-4T-1.5
- 2 : HCT/ATEX-71-4T-2
- 3 : HCT/ATEX-71-4T-3
- 4 : HCT/ATEX-71-4T-4

4T=1500 rpm

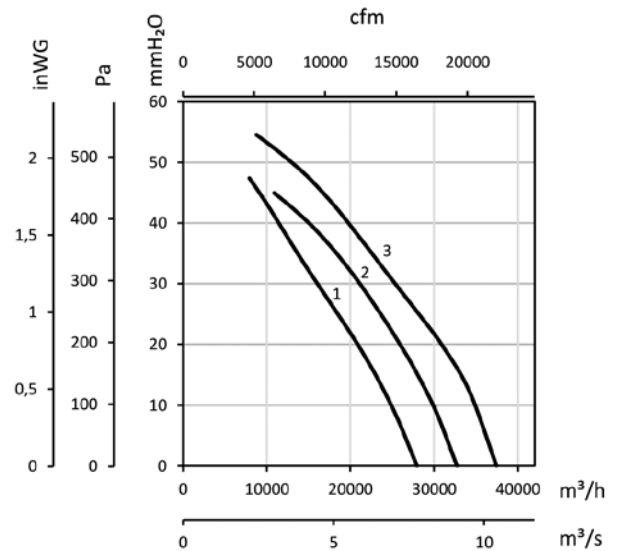

- 1 : HCT/ATEX-80-4T-3
- 2 : HCT/ATEX-80-4T-4
- 3 : HCT/ATEX-80-4T-5.5

4T=1500 rpm

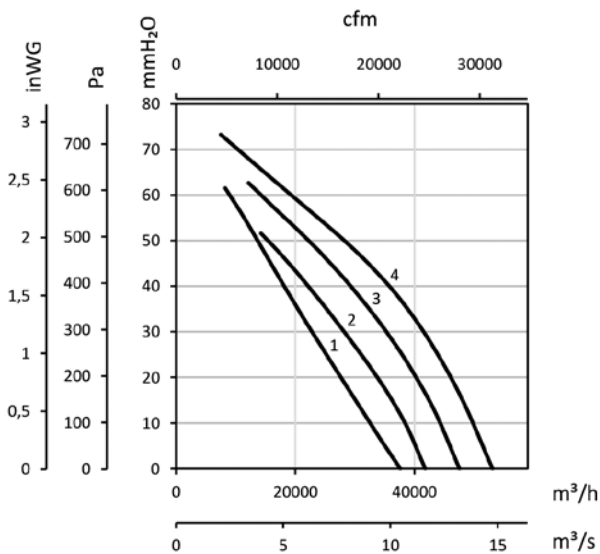

- 1 : HCT/ATEX-90-4T-4
- 2 : HCT/ATEX-90-4T-5.5
- 3 : HCT/ATEX-90-4T-7.5
- 4 : HCT/ATEX-90-4T-10

4T=1500 rpm

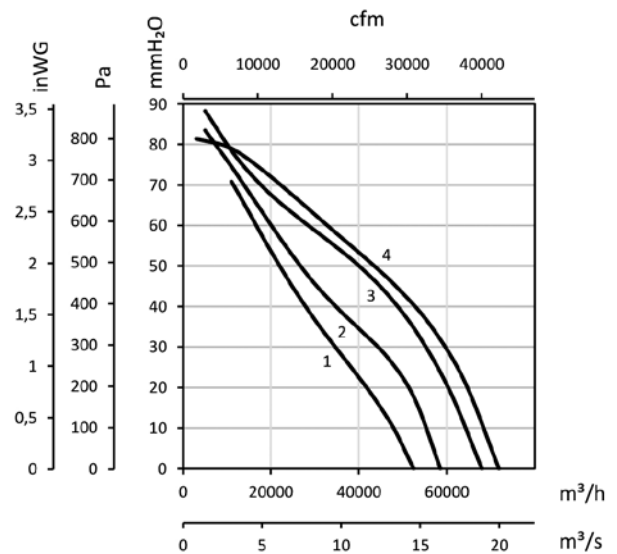

- 1 : HCT/ATEX-100-4T-7.5
- 2 : HCT/ATEX-100-4T-10
- 3 : HCT/ATEX-100-4T-15
- 4 : HCT/ATEX-100-4T-20

Ominaiskäyrät

Q= Ilmamäärä m³/h, m³/s ja cfm

Pe= Staattinen paine mmH₂O, Pa ja inWG

6T=1000 rpm

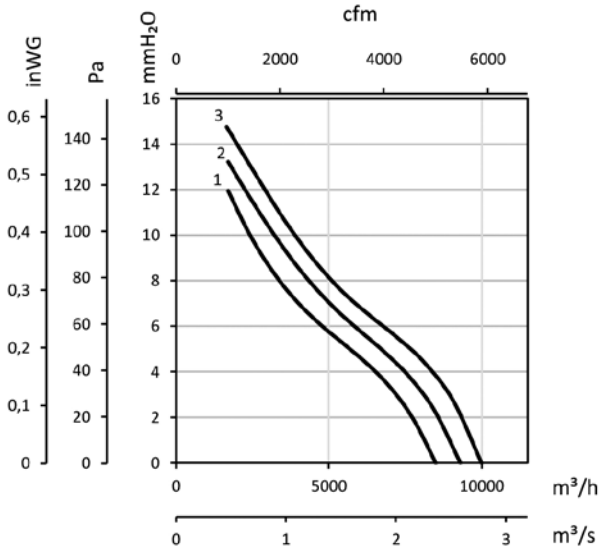

1 : HCT/ATEX-56-6T-0.33
2 : HCT/ATEX-56-6T-0.5
3 : HCT/ATEX-56-6T-0.75

6T=1000 rpm

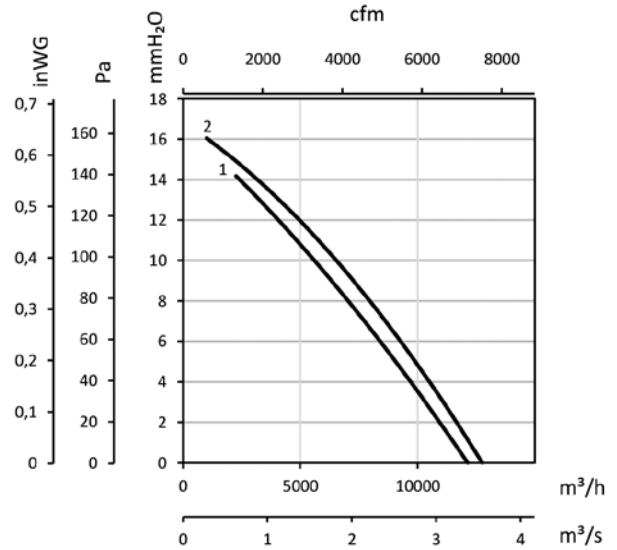

1 : HCT/ATEX-63-6T-0.5
2 : HCT/ATEX-63-6T-0.75

6T=1000 rpm

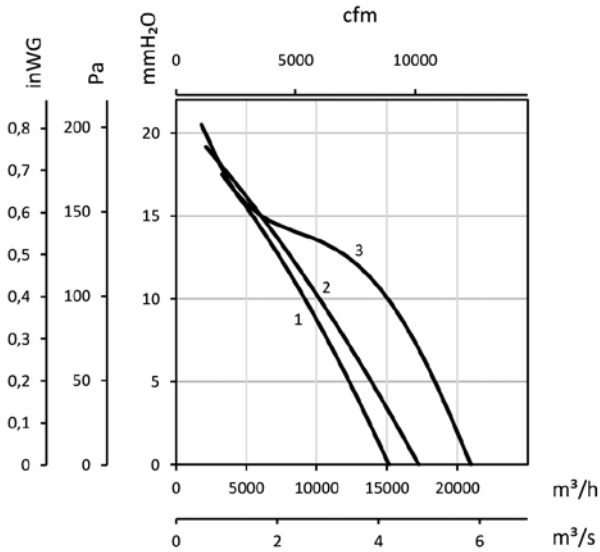

1 : HCT/ATEX-71-6T-0.75
2 : HCT/ATEX-71-6T-1
3 : HCT/ATEX-71-6T-1.5

6T=1000 rpm

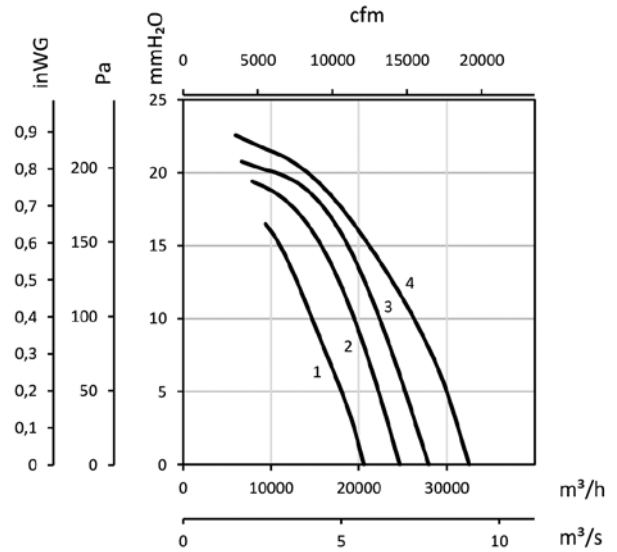

1 : HCT/ATEX-80-6T-1
2 : HCT/ATEX-80-6T-1.5
3 : HCT/ATEX-80-6T-2
4 : HCT/ATEX-80-6T-3

Ominaiskäyrät

Q= Ilmamäärä m³/h, m³/s ja cfm

Pe= Staattinen paine mmH₂O, Pa ja inwg

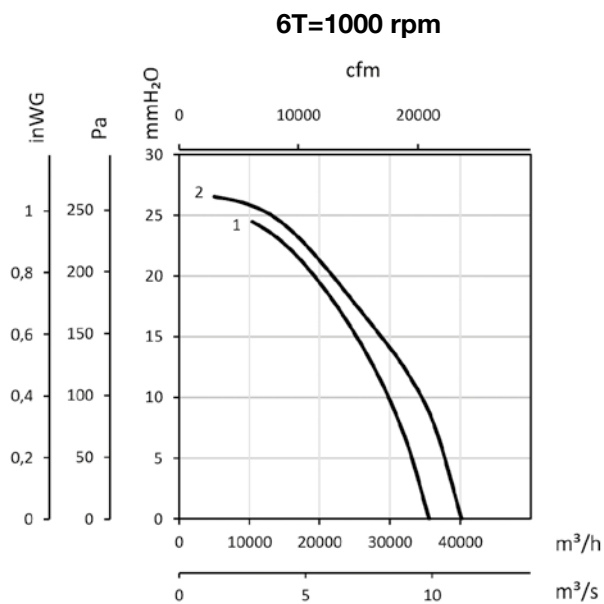

1 : HCT/ATEX-90-6T-3
2 : HCT/ATEX-90-6T-4

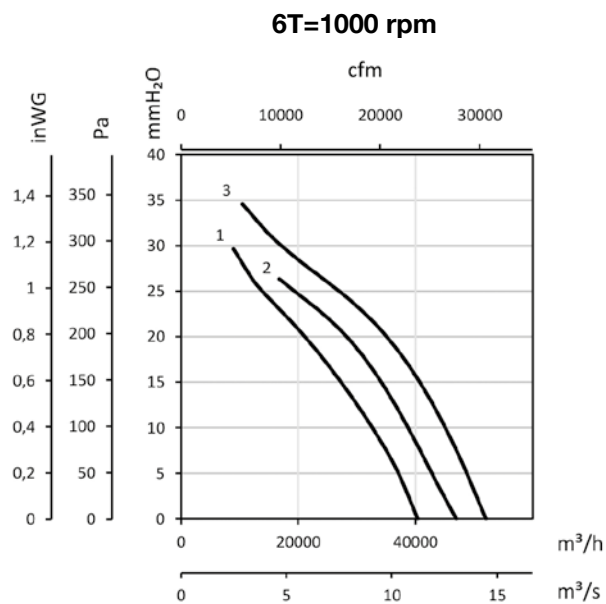

1 : HCT/ATEX-100-6T-3
2 : HCT/ATEX-100-6T-4
3 : HCT/ATEX-100-6T-5.5

Lisävarusteet



INT/ATEX



P

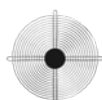

RT



PV



BTUB



PS



PT



PT/H



S